



# BLACK BOX<sup>®</sup>

## NETWORK SERVICES

© 2000. All rights reserved.  
Black Box Corporation.

Black Box Corporation • 1000 Park Drive • Lawrence, PA 15055-1018 • Tech Support: 724-746-5500 • www.blackbox.com • e-mail: info@blackbox.com

## SERVSWITCH<sup>™</sup> CAT5 BROADCAST VIDEO SYSTEM

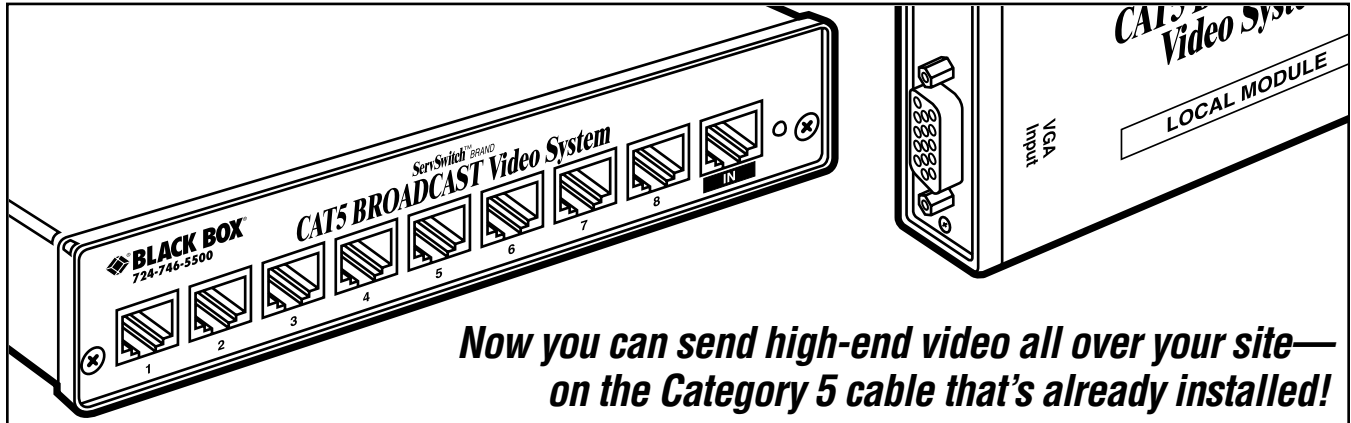

**Now you can send high-end video all over your site—  
on the Category 5 cable that's already installed!**

### Key Features

- ▶ **Drive video from one source to as many as 128 destinations.**
- ▶ **Use inexpensive, modular CAT5 cable.**
- ▶ **Supports total end-to-end cable lengths up to 1000 ft. (300 m).**
- ▶ **Enough bandwidth to handle 1280 x 1024 resolution at 90 Hz.**
- ▶ **Hub has a universal power supply for use almost anywhere.**
- ▶ **Local and Remote Modules are actually powered by the Hub across the CAT5 cable!**
- ▶ **Designed for VGA, but can support almost any kind of video with the right cabling.**

Category 5 cable: Economical, readily available, easy to work with. Maybe you already have a lot of it installed at your site. Wouldn't it be nice to be able to use it in the video-distribution system you have in mind?

With our ServSwitch<sup>™</sup> CAT5 Broadcast Video System, you can! The Broadcast System can distribute a video signal from a single source to as many as 128 monitors or other destination devices across regular Category 5 cable.

It's designed to use VGA, but with the proper cabling and signal conversion (and as long as the destination devices can handle it), almost any video device can be involved—TVs, VCRs, cameras, projectors, DVD players, or even LCD panels or plasma displays.

This is because the System can handle almost any kind of video synchronization: RGBHV (as used in VGA, SVGA, and other types of computer video); RGBS; RGsB ("sync on green"); NTSC, PAL, or SECAM TV composite, and Y/C (also known as "S-Video").

With 120 MHz of bandwidth, the Video System can support resolutions as high as 1280 x 1024 at refresh rates up to 90 Hz. And it can transmit all of that across total end-to-end cable distances as high as 1000 ft. (300 m)!

Here's how it works:

Attach your computer or other source device to the VGA port on a single Local Module (product code ACL8501A). The Local Module will reformat the video signal and send it over CAT5 cable to a Hub. (You can attach a local monitor to it, too.)

The Hub (ACL8500A) is the center of the System. It takes the video input from the Local Module and splits it into eight CAT5 video outputs for Remote Modules or other Hubs. While it does this, it also sends DC voltage across two of the wires on the CAT5 cables to power all attached Modules!

Attach a monitor or other destination device to the VGA port on each regular Remote Module (ACL8502A) or Dual Remote Module (ACL8503A). The Remote Modules adapt the video back

onto standard cable. The Dual Remote Module has an extra pass-through port that you can use to daisychain to an additional Remote Module.

To reach the maximum configuration of 128 destinations, you would attach eight secondary Hubs to a primary Hub, then connect eight Dual Remote Modules to each secondary Hub, and finally connect a regular Remote Module to each Dual Module.

All of the System's video signals (as well as the Modules' power) are carried on a single Category 5 cable pinned according to the TIA-568B standard. The System is compatible with both shielded and unshielded twisted pair. Unlike other products of this type, you can use the same components (Hubs, Modules, and cabling) whether your distances are very short or very long.

All System units are rackmountable in only 1U of vertical rack space.



**With the ServSwitch CAT5 Broadcast Video System, you can attach as many as 128 remote monitors to reach every corner of your site.**

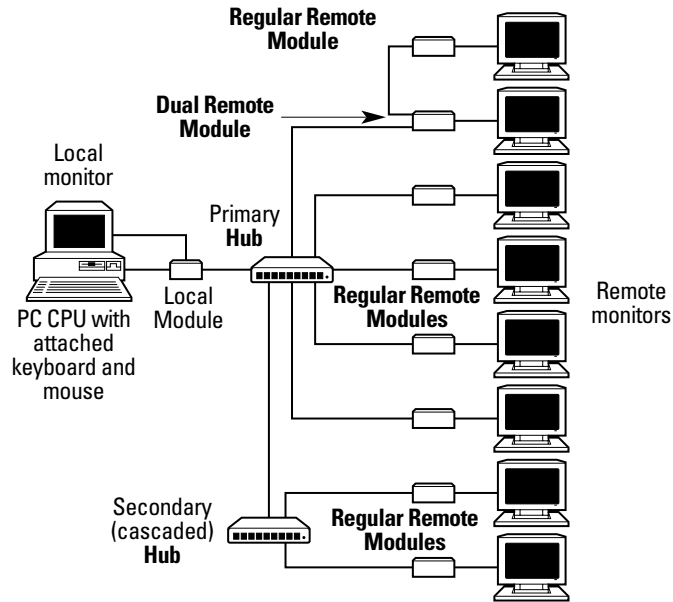

## Specifications

**Compliance:** CE; FCC Part 15 Subpart B Class A, IC Class/classe A

**Standards:** VGA, SVGA, XGA, or XGA-2 video

**Interface:** VGA

**Supported Video Types:** RGBHV (VGA, SVGA, XGA, or XGA-2), RGBS, RGsB ("sync on green"), TV (NTSC, PAL, or SECAM), and Y/C (S-Video)

**Resolution and Refresh Rate:** Up to 1280 x 1024 noninterlaced at up to 85 Hz (depends on distance)

**Maximum Distance:** Up to 1000 ft. (304.8 m) of Category 5 cable between the Local Module and any Remote Module

**User Controls:** On Remote Modules (ACL8502A and ACL8503A): Right-side-mounted Focus dial

**Indicators:** (1) Power LED on each system component

### Connectors:

- On Hub (ACL8500A):
- (9) Front-mounted RJ-45 female:
    - (1) for video input from Local Module,
    - (8) for video output to Remote Modules;
  - (1) Rear-mounted 6-pin DIN female for power;

### Connectors (continued):

- On Local Module (ACL8501A):
- (1) Left-side-mounted HD15 male for video input from source device;
  - (1) Right-side-mounted HD15 female for pass-through video output to a local monitor or other destination device;
  - (1) Right-side-mounted RJ-45 female for video output to, and power input from, Hub;

- On regular Remote Module (ACL8502A):
- (1) Left-side-mounted RJ-45 female for video and power input from Hub;
  - (1) Right-side-mounted HD15 female for video output to destination device;

- On Dual Remote Module (ACL8503A):
- (2) Left-side-mounted RJ-45 female:
    - (1) for video and power input from Hub,
    - (1) for pass-through video and power output to a regular Remote Module;
  - (1) Right-side-mounted HD15 female for video output to destination device

**Maximum Altitude:** 10,000 ft. (3048 m)

**Temperature Tolerance:**  
Operating: 32 to 104°F (0 to 40°C);  
Storage: -4 to +140°F (-20 to +60°C)

**Humidity Tolerance:** Up to 80% noncondensing

### Enclosure:

Hub: Steel;  
Local and Remote Modules: Aluminum

**MTBF:** 300,000 hours (calculated estimate)

### Power:

Hub: From utility-power (mains) outlet, through included detachable input cord and external universal power supply:  
Input: 90 to 260 VAC at 47 to 63 Hz (autosensing);  
Output: +12 VDC at 4.2 A and -12 VDC at 4.2 A;  
Consumption: 7.2 watts plus 140 mW for any attached Local Module and 175 mW for each attached Remote Module;

### Power (continued):

Local Unit: From Hub, on Pins 7 and 8 of the Category 5 cable between them:  
Input: 24 VDC at 100 mA;  
Consumption: 2.4 watts;  
Remote Units: From Hub, on Pins 7 and 8 of the Category 5 cable between them:  
Input: 24 VDC at 125 mA;  
Consumption: 3 watts

### Size:

Hub: 1.5"H x 6.75"W x 7.2"D (3.8 x 17.2 x 18.3 cm);  
Local Module: 1.2"H x 4.5"W x 2.75"D (3 x 11.5 x 7 cm);  
Remote Modules: 1.2"H x 5.5"W x 2.75"D (3 x 14 x 7 cm)

### Weight:

Hub: 2 lb. (0.9 kg);  
Local Module: 3.9 oz. (110 g);  
Remote Modules: 4.6 oz. (130 g)

## The complete package

When you order a ServSwitch CAT5 Broadcast Video System Hub, you'll get:

- The Hub itself.
- Its autosensing power supply.
- The manual for the whole Video System.

When you order a Video System Local or Remote Module, you'll get the Module and its install sheet.



# Ordering Information

## ITEM

## CODE

ServSwitch™ CAT5 Broadcast Video System	
Hub.....	ACL8500A
Local Module.....	ACL8501A
Remote Module.....	ACL8502A
Dual Remote Module.....	ACL8503A
Category 5 Unshielded Twisted-Pair Cable (specify length).....	EYN832A
VGA Video-Extension Cable (HD15 male to HD15 female, specify length).....	EVNPS05-MF

### You might also need...

**CAUTION:** If you use adapters or converters to attach non-VGA equipment, *all* destination devices must be capable of handling the video signals from *all* source devices. For example, driving high-end workstation video to a monitor whose maximum refresh rate is too low could result in oversyncing and damaging the monitor.

Video to VGA Portable (converts NTSC/PAL to VGA up to 1280 x 1024 at 60 Hz).....	AC328A
VGA to Video Portable II (converts VGA up to 1024 x 768 at 75 Hz to NTSC/PAL).....	AC325A-R2
Mac® to VGA Video Adapter (DB15 male to HD15 female).....	EVMA22
Sun® to VGA Video Adapter (13W3 male to HD15 female).....	FA8500SUN
SGI™ to VGA Video Adapter (13W3 male to HD15 female).....	FA8500SGI
Universal Generic Video Adapter (five BNC male to HD15 female, handles any sync arrangement).....	EYRGS4-0006
Rackmount Kits for 19" Racks (each Kit uses only 1U of vertical space):	
Kit for mounting a single Hub.....	RMK8500
Kit for mounting as many as six Local or Remote Modules.....	RMK8501

*Call us about UPSes and AC-power surge protection; we'll help you determine the best equipment for your application.*

## Why Buy From Black Box? Exceptional Value. Exceptional Tech Support. Period.

### Recognize any of these situations?

- You wait more than 30 minutes to get through to a vendor's tech support.
- The so-called "tech" can't help you or gives you the wrong answer.

- You don't have a purchase order number and the tech refuses to help you.
- It's 9 p. m. and you need help, but your vendor's tech support line is closed.

According to a survey by Data Communications™ magazine, 90% of network managers surveyed say that getting the

technical support they need is extremely important when choosing a vendor. But even though network managers pay anywhere from 10 to 20% of their overall purchase price for a basic service and support contract, the technical support and service they receive falls far short of their expectations—and certainly isn't worth what they paid.

At Black Box, we guarantee the best value and the best support. You can even consult our Technical Support Experts before you buy if you need help selecting just the right component for your application.

Don't waste time and money—call Black Box today.

