



© 2003. All rights reserved.
Black Box Corporation.

BLACK BOX[®]

NETWORK SERVICES

Black Box Corporation • 1000 Park Drive • Lawrence, PA 15055-1018 • Tech Support: 724-746-5500 • www.blackbox.com • e-mail: info@blackbox.com

NETRACK PLUS

NetRack and accessories neatly hold your equipment and cables.

Key Features

- ▶ **Ample interior space to fit bulky cables.**
- ▶ **Fully assembled.**
- ▶ **Locking doors.**
- ▶ **Simply remove the side panels to join the NetRack Plus to other racks or cabinets.**
- ▶ **Compatible with Comm Cabinet accessories.**

The NetRack Plus is a fully assembled, ready-to-use cabinet. Just add your equipment and plug it in—that's it! See the illustration on **page 2** for a list of the NetRack Plus's features.

Additional features:

- Ample space inside the cabinet—large bundles of wire and cable fit without a problem.
- Fully welded and assembled, constructed of heavy 12-gauge steel, with a 3000-pound (1360.8-kg) load rating.

- Locking doors provide quick access and security.
- The PLEXIGLAS[®] door can easily be changed from left-to-right-opening with quick-release pins.
- Easily join the NetRack Plus frame to other racks or cabinets—just remove the side panels.
- For extra shelving, order sliding, fixed solid, or fixed vented shelves.
 - The Sliding Shelf (RM170-R2) holds 75 pounds (34 kg) and measures 22.63" (57.5 cm) deep.

- The Fixed Solid Shelf (RM171) and the Fixed Vented Shelf (RM172-R2) each support up to 100 pounds (45.4 kg) and measure 23" (58.4 cm) deep.
- Our Comm Cabinet accessories will fit this cabinet. See **page 3** for a list of compatible products, or check your BLACK BOX[®] Catalog for additional information.

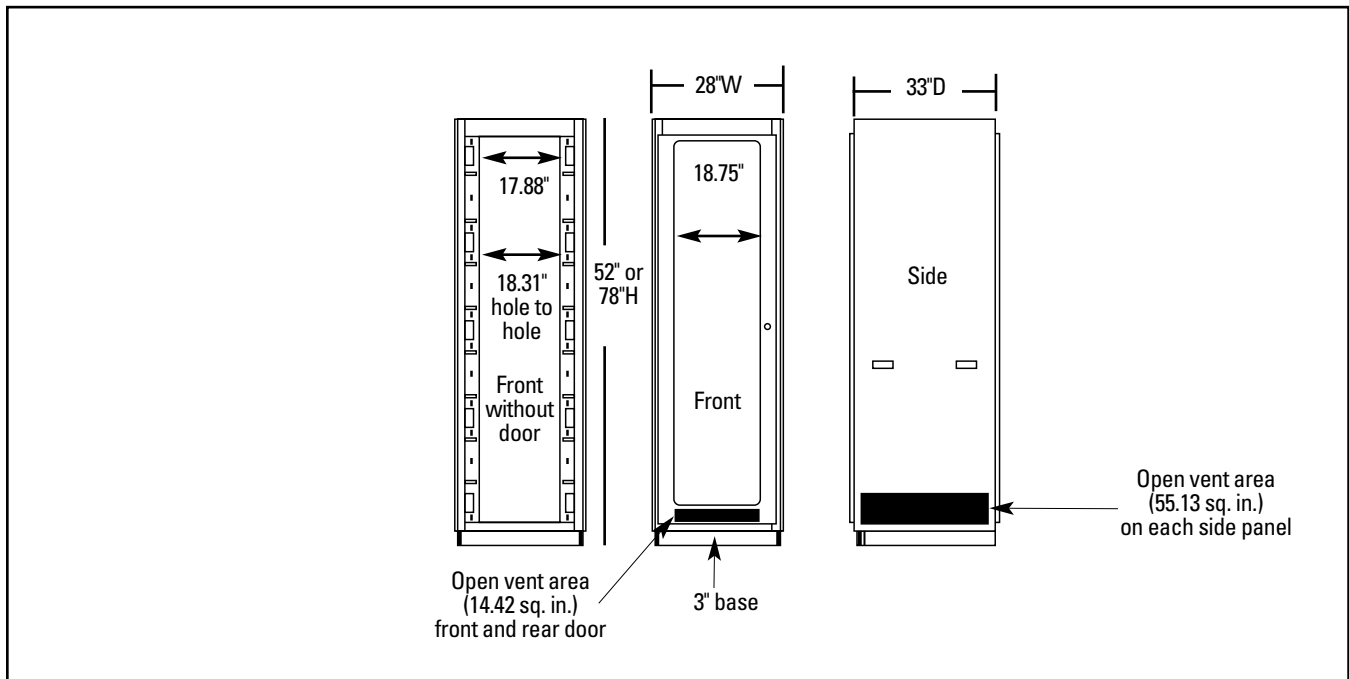

Organize your equipment and cables with the NetRack Plus.

The NetRack Plus contains four full-length vertical organizers with front-to-rear and inside-to-outside cable feed-through holes.

19" rails meet EIA-310-D standards and contain $\frac{10}{32}$ " mounting holes and bridge lances for securing cable. Heavy-duty reusable ties included.

Vertical cable organizers feature cable feed-through holes and cable rings.

Ladder rack mounting holes accept 6", 9", 12", and 15" wide ladder.

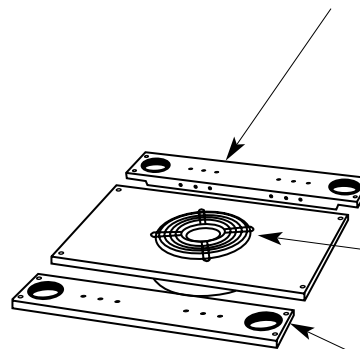

15" panel with 10" 550-CFM exhaust fan.

Overhead interior lighting.

Cable access panels contain 3" holes with grommets and plugs. Soft grommets protect cable and prevent kinks.

Modular top panels can be field-adjusted to accommodate various cooling and cable-management scenarios.

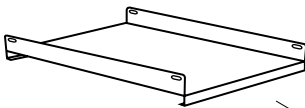

Heavy-duty equipment shelf.

Shelving options include:

Sliding Shelf (RM170-R2).

It features a 75-pound (34-kg) capacity. It's 22.63" (57.5 cm) deep—almost as deep as the fixed shelves.

Fixed Solid Shelf (RM171). It's 23"

(58.4 cm) deep and can support up to 100 pounds (45.4 kg).

Fixed Vented Shelf (RM172-R2).

It's 23" (58.4 cm) deep and can support up to 100 pounds (45.4 kg).

Durable frame allows for a 3000-lb. load rating.

16-gauge rear door with lock, bottom vents, and removable hinge pins.

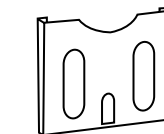

8.5" x 11" storage pocket on rear door holds equipment manuals.

Front PLEXIGLAS® door has a lock, bottom vent, and removable hinge pins.

Modular, vented side panels feature easy-lift handles.

Six-outlet power strip (125 V, 15 amps).

A pontoon base has leveling feet and power-cord access hole.

Set of 4 full-swivel, heavy-duty casters (rated at 200 lb. each) is available.

Open bottom provides room for cable entry and exit.

Specifications

Interior Panel Space Width:
19" (48.3 cm)

Exterior Width: 28.28" (71.8 cm)

**Interior Opening Height
(without Door):** RM550A-R2,
RM555A-R2: 43.75" (111.1 cm);
RM560A-R2, RM565A-R2:
70" (177.8 cm)

Overall Height: RM550A-R2,
RM555A-R2: 52" (132.1 cm);
RM560A-R2, RM565A-R2:
78" (198.1 cm)

Depth: 33" (83.8 cm)

Material: 12-gauge steel

Rack Spaces: RM550A-R2,
RM555A-R2: 25U;
RM560A-R2, RM565A-R2: 40U

Size: RM550A-R2, RM555A-R2:
52"H x 28"W x 33"D
(132.1 x 71.1 x 83.8 cm);
RM560A-R2, RM565A-R2:
78"H x 28"W x 33"D
(198.1 x 71.1 x 83.8 cm)

Shipping Weight: RM550A-R2,
RM555A-R2: 241 lb. (109.3 kg);
RM560A-R2, RM565A-R2:
315 lb. (142.9 kg)

Why Buy From Black Box? Exceptional Value. Exceptional Tech Support. Period.

Recognize any of these situations?

- You wait more than 30 minutes to get through to a vendor's tech support.
- The so-called "tech" can't help you or gives you the wrong answer.
- You don't have a purchase order number and the tech refuses to help you.
- It's 9 p.m. and you need help, but your vendor's tech support line is closed.

According to a survey by Data Communications magazine, 90% of network managers surveyed say that getting the technical support they need is extremely

important when choosing a vendor. But even though network managers pay anywhere from 10 to 20% of their overall purchase price for a basic service and support contract, the technical support and service they receive falls far short of their expectations—and certainly isn't worth what they paid.

At Black Box, we guarantee the best value and the best support. You can even consult our Technical Support Experts before you buy if you need help selecting just the right component for your application.

Don't waste time and money—call Black Box today.

Compatible Comm Cabinet Accessories

- Short Steel Doors
- Long Steel Door, Vented
- Fan Trays
- Filler Panels
- Plexidoors
- Door Lock

Ordering Information

| ITEM | CODE |
|------------------------------------|-----------|
| NetRack Plus | |
| 52" | |
| Black..... | RM550A-R2 |
| Beige..... | RM555A-R2 |
| 78" | |
| Black..... | RM560A-R2 |
| Beige..... | RM565A-R2 |
| NetRack Plus Accessories | |
| Shelves (Black) | |
| Sliding..... | RM170-R2 |
| Fixed Solid..... | RM171 |
| Fixed Vented..... | RM172-R2 |
| Heavy Duty Casters (Set of 4)..... | RM173-R3 |